

## June 2007 Theme -- "Wheel Into Summer"

Wheels help us have a "wheely" good time. Our bicycles, skateboards, roller blades, and scooters are fun provided we use them correctly. Learn about how bikes are used in other countries and in various types of competitions. How about having a pack "Wheel Fun Party" where you can demonstrate your skills and learn safety rules while having lots of fun? Remember to wear the correct protective gear such as helmets and pads. Conduct a pack Cubmobile race. Adult family members can be judges and help with a cookout or picnic. Don't forget to look into electives that could be completed during the meeting as well as earning the Bicycling and Skating belt loops and pins.

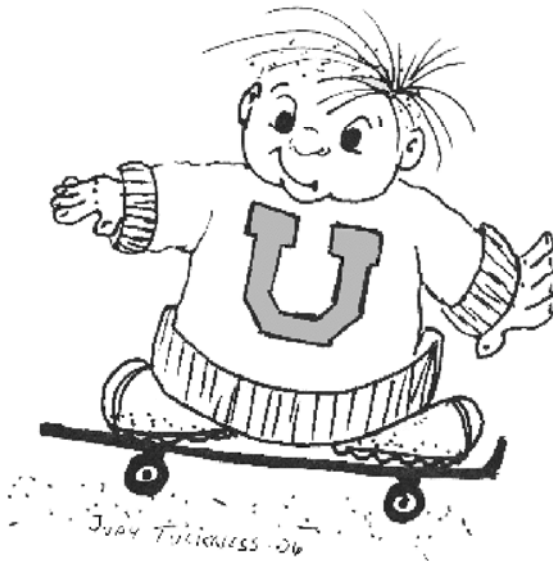

Webelos Activity Badges for June 2007: Traveler and Artist

Starting in May 2007 you will find the latest edition of Baloo's Bugle at <http://www.usscouts.org/bbugle/bb0705/index.html>. The following resources are supplements to your monthly Program Helps.

### **SPECIAL OPPORTUNITY**



#### **Bicycle Belt Loop and Pin**

##### **Belt Loop**

Complete these three requirements:

1. Explain the rules of safe bicycling to your den leader or adult partner.
2. Demonstrate how to wear the proper safety equipment for bicycling.
3. Show how to ride a bike safely. Ride for at least half an hour with an adult partner, your family, or your den.

##### **Sports Pin**

Earn the Bicycling belt loop, complete requirement 1 below, and do four additional requirements

1. Make a chart to record at least 10 hours of bicycling. (Required)
2. Participate in a pack, den, or community bike rodeo.
3. Demonstrate how to repair a flat tire on a bicycle.
4. Make a poster illustrating different types of early bikes and show it to your den.
5. Give a demonstration to your den or pack on the proper use of safety equipment and gear.
6. With the help of a parent or adult partner, register or reregister your bicycle.
7. Go on a "bicycle hike" with your family or den. Obey traffic rules related to bicycling.
8. Repair or restore a nonfunctioning bicycle to a safe condition. Include the installation of all proper safety devices.
9. Visit a bicycle race or exhibition.
10. Help set up a bike rodeo or bike competition for your pack.



## Roller Skating Belt Loop and Pin

### Belt Loop

#### Complete these three requirements:

1. Explain ways to protect yourself while roller skating or inline skating, and the need for proper safety equipment.
2. Spend at least 30 minutes practicing the skills of roller skating or inline skating.
3. Go skating with a family member or den for at least three hours. Chart your time.

### Sports Pin

#### Earn the Roller Skating belt loop, and complete five of the following requirements:

1. Participate in a pack or community skating event.
2. Demonstrate how to disassemble and reassemble skates.
3. Explain the proper clothing for roller or inline skating.
4. Spend at least 30 minutes, on two occasions, practicing warm up exercises before skating.
5. Play a game of roller hockey,
6. Learn two new roller skating skills: Forward Scissors, Forward Stroking, Crossover, or Squat Skate.
7. Participate in a roller or inline skating skill development clinic.
8. Demonstrate how to stop quickly and safely.
9. Demonstrate how to skate backwards. Skate backwards for five feet.
10. Play a game on roller skates, roller blades, or inline skates.

*The Cub Scout Sports Roller Skating activity includes roller skating and inline skating (roller blading). See [Ice Skating](#) for information pin and belt loop requirements for ice skating.*

## TIGERS

### Picnic Fun/ Fun Outdoors

***This is a great opportunity to take your Tigers out for a picnic at a local state or city park and walk around and see what they have you can learn about Your Home State CD Family Activity***

- Take a bike ride. (Be certain to practice bicycle safety.)
- Play catch or Frisbee.
- Go roller-skating or -blading. (Always wear protective gear.)
- Visit the zoo.
- Plant a flower and/or vegetable garden.
- Visit a nearby playground or park.
- Have a barbecue or picnic at a park.
- If you cannot get to the park, have a picnic in your backyard.
- Did your picnic get rained out? Do not despair. Do it indoors - complete with blankets, paper plates, cups, etc.
- Go fishing.
- Take a paddle boat ride.
- Go swimming in a creek or pond (Practice water safety, of course!)
- Take a blanket and several books outside and read under the shade of a tree.
- Make homemade ice cream.
- Wash the car together. This can be great fun on a hot day!
- Camp out in the backyard.

## **Frisbee Golf**

This is a great game that can be set up in a backyard, in a park or around a neighborhood. The basic idea is that you have laundry baskets or some other sort of receptacle, some flags or a way to see the receptacle and a few Frisbees. Just like regular golf, you try to land your Frisbee in the "hole" in as few shots as possible.

## **Make homemade ice cream.**

You can get a freezer for about \$20. Pick up a bag of ice, rock salt, a gallon of low-fat milk, and a can of non-fat Eagle Brand. Let your child mix the Eagle Brand, a cup of sugar, 1/8 t salt, and tablespoon of vanilla extract with about two cups of milk. Stir until the sugar has dissolved, then pour into the freezer. Add more milk to the fill line, load it up with ice and rock salt, and let it run for about 40 minutes.

## **Watermelon and Sprinkler.**

Watermelons are so sticky and messy in the house. Instead, just cut a whole watermelon into enough pieces for your family and their friends then send them outside and turn on the sprinkler. You don't even have to watch it; just let them loose to get as sticky and wet as they want.

## **Den Activity**

Put up a hoop for basketball or suggest the boys get active with skipping, tag, racing, baseball, soccer or swimming. Always emphasize the fun and not the competition.

Go fly a kite! (If you don't have one, make one!)

Study the shapes of passing clouds, then use cotton balls and glue on paper to recreate the images they saw.

## **Bubble solution**

Start by mixing together 1/4 cup of dishwashing liquid, 2 cups of water, and 1 teaspoon of sugar. Pour the mixture into a shallow container.

## **Bubble Mania**

Have a bubble blowing frenzy using a variety of unusual bubble blowing tools! Plastic funnels, six pack soda rings, plastic cups with holes punched through the bottom.

## **Bubble Art**

Now take the bubble mix, pour some into a cup and add a few drops of food coloring. Blow rainbow bubbles into the air, and try to catch them with a white sheet of paper! After the paper dries, use markers or crayons to finish your masterpiece!

## **Pet Rocks**

Find smooth, flat or round rocks. Be sure to clean off any dirt or sand and dry completely before starting. Paint with acrylic paints. Decorate faces by using googly eyes, yarn for hair, markers, glitter, and any other tidbits you like.

# GATHERING ACTIVITIES

## Water Word Search

*This puzzle contains words and phrases related to Water Fun and Safety. See how many you can find.*

X G Z D S G G Y O I P A N J U B Z W T E  
R C C K P K F N G Z P T T T E G C V H B  
M T Y Y J E G T I N P L G E Z H R M G X  
P N U S K S K T A F F W N W F I M O W M  
Q K K P Q W N A F O R U I Z O Y C M I A  
B M A R C O P O L O B U H D G B Q F Y T  
Z K G I H K D L O Y J L S M R U Y N X X  
X T W N K N O F A L R R I W U D F P A L  
D J A K L U A A T H L O F A M D S W X F  
M D P L N Z H Y I X R A M T S Y G X P G  
N B G E E E D T N B G T B E J S N S S Q  
Y C N R O W M E G F H A L R M Y I N O L  
K G A S X A T F R B J U I S E S L Z O M  
C Y N O Y X D A I M R T F K D T I Y T J  
F B F I P H J S O Y A I E I H E A L J G  
J C G W T I D L E B Z S G I O M S W Q S  
B R M U P A P B W K W F U N F U N F U N  
X I N V Q M O C E J Q O A G R P A R V R  
V Q C U V W K B R Z V C R B L M U L C W  
Q A J H W C M E J O R F D A F G Z W B K

BOATING  
BUDDY SYSTEM  
CANOE  
FISHING  
FLOATING  
FUN FUN FUN

LIFEGUARD  
MARCO POLO  
MEMORY LAKE  
OBEY RULES  
PFD  
ROW BOAT

SAFETY  
SAFETY AFLOAT  
SAIL BOAT  
SAILING  
SPRINKLERS  
SURFING

## Water Showdown

Whoever said all pre-opening activities have to be done inside? No one! Try this one. As the folks arrive, pair them off for the great showdown. Take them outside where you have enough water pistols handy to run water pistol duels. Each person gets up to five squirts at the "bad guy."

## Nature Did It First

For most modern inventions, there exists a counterpart in nature. Here is a list of animals and the invention they utilize. Try matching the animal with the invention.

Animal	Invention
1. Bat	A. Parachute
2. Armadillo	B. Snowshoes
3. Chameleon	C. Anesthetic
4. Fish	D. Helicopter
5. Flying Squirrel	E. Suction Cup
6. Squid	F. Hypodermic Needle
7. Hummingbird	G. Radar
8. Scorpion	H. Camouflage
9. Snake	I. Electricity
10. Abalone	J. Tank
11. Caribou	K. Jet Propulsion

Answers: 1-G, 2-J, 3-H, 4-I, 5-A, 6-K, 7-D, 8-F, 9-C, 10-E, 11-B

### Owl Puzzle

Hoo? Hoo? Who will be the wise owl to reach the perch in the center without running into a bull's-eye?

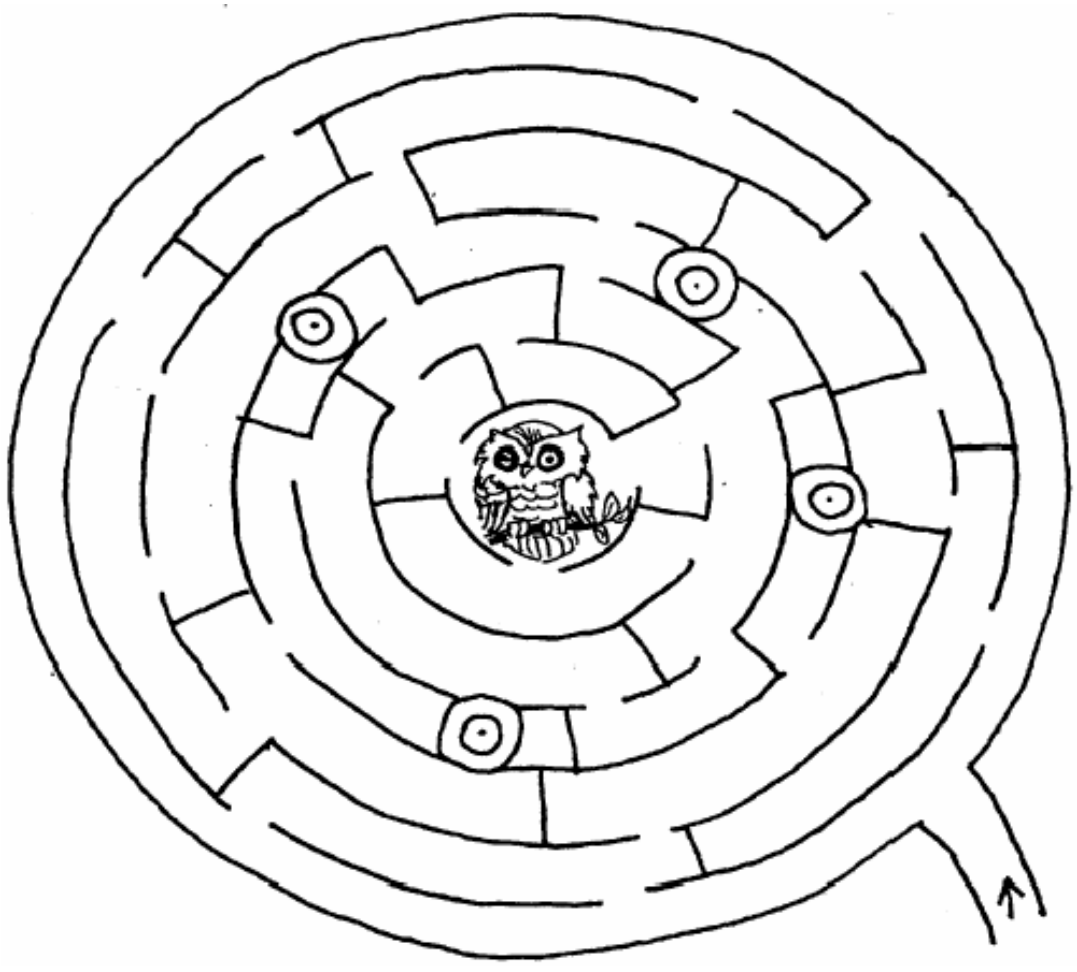

## Outdoor Fun

San Gabriel Valley, Long Beach Area, Verdugo Hills Councils

G N I K C A P K C A B W D C J  
G E I X V S Z J M K A Y O T L  
C S L Q Z B Z S O L B I O Y Y  
M A P T W F R C K B V G F A S  
D H M I T O U I S U N E N H N  
T L R P O O N S T N E T U I I  
B K H D I G B A C K P A C K A  
L M T C S N S R Q M N B V I T  
A U V T I H G T E N P L A N N  
O I I Z O A A E O T A Q I G U  
C C A R T O C J V O A N J P O  
K D T A W X K R M F B W A G M  
O S E N K Q H U T F B L C Q Z  
V H Q H Q L O T W C N B I O U  
T M A X X O G D B A O O U U M

BACKPACK  
BACKPACKING  
HEAT  
SHORTS

WALKINGSTICK  
BOOTS  
HIKING  
WATERBOTTLE

SUN  
CAMPING  
MOUNTAINS  
SUN

TENTS  
FOOD  
OUTDOORS

## OPENING CEREMONIES

### The Outdoor Code Opening Ceremony

**Materials:** The American flag posted on the stage, several potted plants or an artificial tree, a garbage bag filled with trash (rinsed out cans, bottles, crumpled paper, etc.)

(The Cubmaster enters carrying the garbage bag, and stands between the flag and the plants.)

**Cubmaster:** We are blessed to live in this great land of freedom and beauty. America truly is the home of amber waves of grain and purple mountains majesty. Unfortunately, there are people in this country who abuse their freedom and pollute the land. (He dumps the bag of trash on the ground.) As Cub Scouts, we can learn to be better Americans by living the Outdoor Code.

**1st Cub:** (enters and stands by Cubmaster) As an American, I will do my best to be clean in my outdoor manners. (He takes empty bag from Cubmaster and begins to pick up trash while Cubmaster speaks.)

**Cubmaster:** I will treat the outdoors as a heritage. I will take care of it for myself and others. I will keep my trash and garbage out of lakes, streams, fields, woods, and roadways.

**2nd Cub:** (enters and takes bag from 1st Cub. 1st Cub exits.) I will be careful with fire. (Picks up more trash as Cubmaster speaks.)

**Cubmaster:** I will prevent wildfire. I will build my fires only where they are appropriate. When I have finished using a fire, I will make sure it is cold out. I will leave a clean fire ring, or remove all evidence of my fire.

**3rd Cub:** (Enters and takes bag from 2nd Cub. 2nd Cub exits.) I will be considerate in the outdoors. (Picks up trash as Cubmaster speaks.)

**Cubmaster:** I will treat public and private property with respect. I will use low-impact methods of hiking and camping.

**4th Cub:** (Enters and takes bag from 3rd Cub. 3rd Cub exits.) I will be conservation-minded. (Picks up remaining trash as Cubmaster speaks.)

**Cubmaster:** I will learn how to practice good conservation of soil, waters, forest, minerals, grasslands, wildlife, and energy. I will urge others to do the same. (4th Cub gives bag back to Cubmaster and exits.) These Cub Scouts have shown they are willing to protect our country's natural beauty and conserve her natural resources. Please stand, salute the flag and join me in singing "America the Beautiful." (Or say the Pledge of Allegiance.)

**Note:** Outdoor Code card (No. 33428) is available for purchase at the Scout Service Center. Give one to each Cub Scout to remind him of this ceremony.

### Four Winds Opening Ceremony

**Personnel:** Four Winds (cub scouts or leaders dressed in Indian costume or in cub scout uniform carrying artificial torches). Cubmaster (dressed as Indian chief)

**Equipment:** Artificial campfire which can be lit by placing an electrical light bulb, covered with red cellophane inside the campfire.

**Cubmaster:** " Let the North Wind enter".

*(One of the cub scouts enters carrying a torch, He stands by campfire and says his line. Others do likewise as they are called in.)*

**North Wind:** "The North Wind that brings the cold builds endurance".

**Cubmaster:** "South Wind , enter".

**South Wind:** "The South Wind brings the warmth of friendship".

**Cubmaster:** "East Wind, enter". East Wind: "The East Wind brings the light of day". Cubmaster: "West Wind, enter".

**West Wind:** "The West Wind from the direction where the sun sinks, brings night and stars.

**Cubmaster:** "The Four Winds will light our council fire".

*All four boys touch their artificial torches to the fire at the same time. At this same moment the light is turned on from offstage "lighting" the campfire..*

### The Den Hike

**Cub 1:** We are going to see nature's treasures.

**Cub 2:** We will help to maintain nature's balance.

**Cub 3:** We will observe and learn from nature's animals.

**Cub 4:** We will help maintain nature's resources.

**Cub 5:** We will protect them from harm.

**Cub 6:** We will follow the Laws of Nature.

**Cub 7:** We are going on a hike.

### Cub Scout Campfire Opening Ceremony

**Equipment:** Real or artificial campfire, seven candles.

**Personnel:** Narrator and seven Cub Scouts (each with his part written on a dip paper).

**Narrator:** Welcome to our Cub Scout campfire. Akela is among us. Let us draw from this campfire with all its vibrancy and warmth, the secrets of Cub Scouting and the spirit of brotherhood.

1. In its light we see new chances to be helpful and to do our best.
2. From its warmth we strengthen the bonds of fellowship and learn how to get along with others.
3. From the stones that ring the fire and keep its power in check, we learn how we can curb our tempers and become good citizens.
4. From the smoke that rises out of the fire, we learn to lift our eyes upward and worship God.
5. The spark that started this fire reminds us that little Good Turns can lead to greater deeds.
6. Just as the fire needs wood to bum brightly, so do we need the care and love of our parents to bum brightly.
7. In its leaping flames, we see the fun of Cub Scouting and the job of life.

## ***PACK AND DEN ACTIVITIES***

### **Speakers –**

- Invite a bicycle mechanic to come and talk with your den or pack. Or arrange to go visit with him or her.
- Arrange for a local mechanic to visit your den or visit his garage, perhaps he can show your den the safe way to change a tire, light bulb and to check the oil and transmission fluid.
- Invite someone from a bicycle club to review safety procedures

### **Field Trips**

- Visit a local bicycle shop and talk with the mechanic to see if he will show you how to do a safety check upon your bike and perform minor adjustments.
- Visit an auto or truck dealership.
- Arrange a visit to a service station. Have the attendant explain the use of different types of equipment (jack, torque wrench, etc.). If possible have the attendant show them how to check oil level, check fluids and belts, check tire pressure, and change light bulbs. Organize a bike rodeo.
- Visit a train station
- Go to a roller rink

### **Activities**

- Put on a bicycle rodeo for your pack or den.
- Have a clinic on the care and repair of bicycles. Set it up like a shop and have each boy bring his bike and do repairs, etc.



# BICYCLE GYMKHANA

The word "gymkhana" comes from India by way of England, where it is used to describe an unusual kind of automobile race. Competition is against the clock, and a variety of driving skills are necessary to qualify with the best time. Here is a gymkhana adapted for bicycles. True to the tradition, speed alone will not give the best time. Instead, a mixture of good balance, accuracy, practice, and a well-maintained bike should carry the day.



Lay out a course on a little-used street, parking lot, or other paved area. Chalk, sticks, small stones, tin cans, even poured sand can all be used to mark the course.

This course is only a suggestion. Use it to get started, but by all means, add your own inventions.

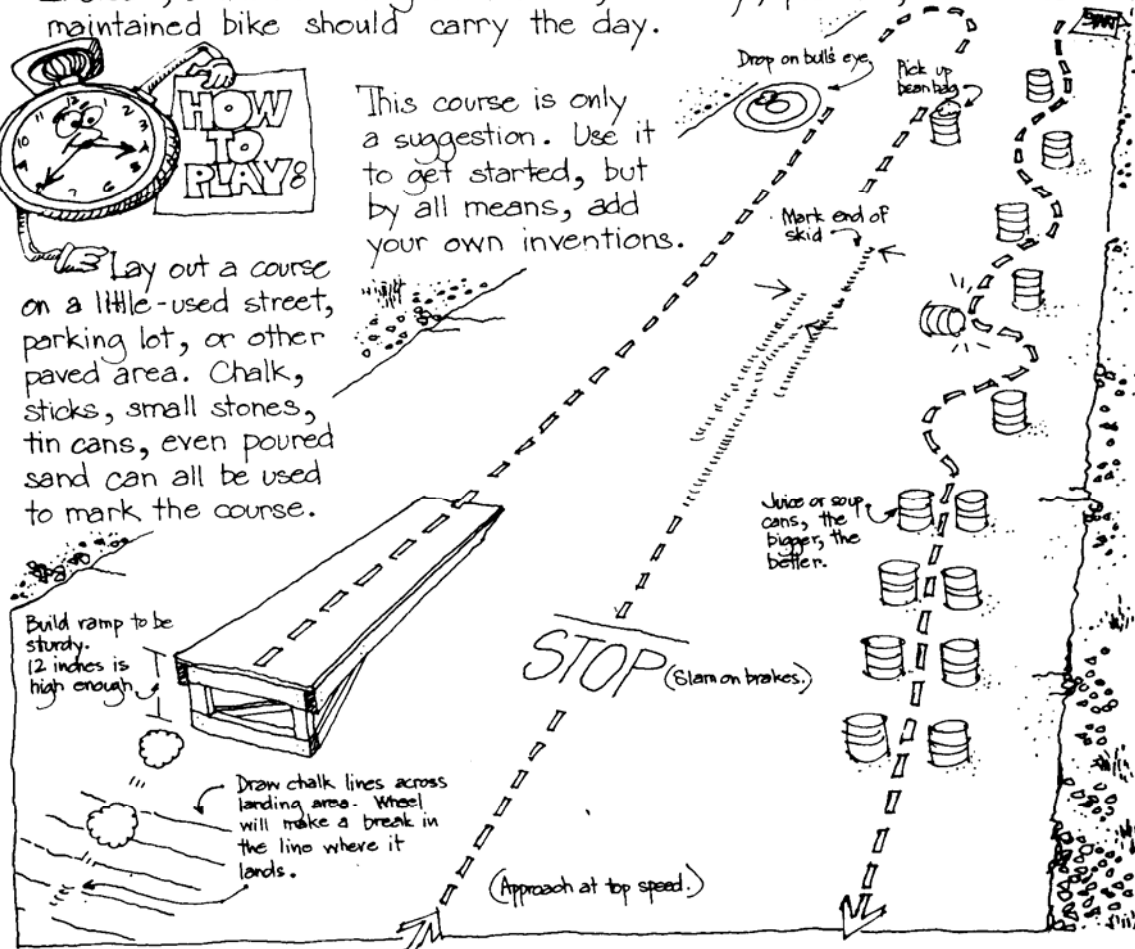

The "winner" is the player who completes the course in the least time... BUT for each can knocked over add 5 seconds. For the shortest stopping time subtract 10 seconds. For the longest jump subtract 10 seconds.

## Bike Rodeo

Here are some ideas for you do run a bike rodeo for your Cub Scouts. The boys and their parents need to be involved in this fun activity. Include traffic safety, bike safety, and bike skills in the activities you choose for the event. **Your local Police Department can probably provide you with complete details on running this event.**

The rodeo should encourage the safety, bike skills and confidence a Cub needs to ride safely. A bicycle is a vehicle with the same rights and responsibilities as other vehicles on the roads. Biking is fun. In order for Cubs to

know if their bikes are safe, contact your local police department. Many will send an officer out to do a bike safety checks. Stress the need to of bike safely - not foolishly. Instill good traffic habits from the start with young riders.

Once a boy learns to ride a bike, he will never forget. If he learns good riding skills when he is young, they will follow him into adulthood. Bicycling is truly a life-long activity.

**Equipment:**

- 50 feet measurer or yard stick
- Chalk, tape or sting - for lines
- Traffic cones or weighted cans
- Score sheets and pencils
- Clipboards - for volunteers
- Stop Sign
- Bicycles and helmets

**Organize** so there is as little waiting as possible.

**Divide** the Cub Scouts and rotate them through the different areas.

**Station One: Inspection Station** – The Cub Scout needs to have his bike checked for safety. Ask your local policeman to come and check the bike.

**Station Two: Ride on the line** – Make a wide line and have the Cub Scout ride his bike down the line. The line should be no longer than 12 feet.

**Station Three: Helmet and bike check** –Check the helmet fit and seat height. Know how to use a lock and cable to secure a bike.

**Station Four: Safe Driving** - Have the Cub Scouts ride their bikes around traffic cones. The leaders can choose the pattern of the cones.

**Station Five: On the Street** - Create an intersection on the parking lot. Have the Cub Scouts demonstrate how to cross an intersection safely.

**Station Six: Steering** - Make a circle with the tape. Have the Cub Scouts ride their bike around the circle, staying on the tape as much as possible.

**Station Seven:** - Recognition Cub Scouts receive recognition for participation in the rodeo and have a snack.

## **Bicycle Safety Quiz**

See how well you know your bicycle safety facts by taking this quiz. Circle the letter for the answer you choose.

1. When approaching a stop sign, I should:
  - a) Look left and right and ride through the intersection without slowing down.
  - b) Slow down and then proceed through the intersection.
  - c) Come to a complete stop, check both directions and then proceed when it is safe.
2. When approaching an intersection with no stop sign or light, the best thing to do is:
  - a) Ride through quickly.
  - b) Slow down, look to the left and right, and watch for tuning vehicles.
  - c) Stop in the middle of the road to see what's coming.
3. When making a turn or stopping on the road, I should use hand signals:
  - a) When a big steamroller is approaching.
  - b) If Mom is watching.
  - c) Every time I turn or stop.
4. On two-way city streets as well as country roads, I should ride on the \_\_\_\_\_ side of the street.
  - a) Left – against traffic
  - b) Right – with traffic
  - c) Left or right, whichever is more convenient
5. When is it okay to carry another person on my bicycle?
  - a) Never.
  - b) If there's not much traffic.

- c) If I stay on the sidewalk.
6. If I am late starting home after dark and my light doesn't work, I should
- Walk my bike home on the sidewalk.
  - Ride on the left side of the street to see cars coming.
  - Ride on the right-hand side of the street.
7. Good ways to be seen at night are by:
- Wearing light-colored clothing and reflective tape.
  - Using bright reflectors, red to the rearm white or amber to the side, and white to the front.
  - Both A and B.
8. The safest way to carry books or other gear on my bicycle is:
- In pack on my back.
  - In a special carrier rack or basket.
  - In a bag in my hand.
9. Leaves on the roadway and painted center lines can be hazardous to cyclists because:
- They distract your attention.
  - They become slippery when wet.
  - They may both be yellow-colored.
10. A good rule when riding in traffic is:
- To listen as well as watch for cars.
  - To weave in and out of parked cars.
  - To yell at motorists who are in your way.
11. If I approach a crosswalk when riding my bike, I should:
- Yell so pedestrians will get out of my way.
  - Stop so that pedestrians may cross.
  - Ride my bike up the curb to avoid hitting anybody.
12. When bicycling with a friend, we should always ride:
- Single file.
  - Two abreast.
  - In no particular pattern.
13. When riding with a group it is best to:
- Tie a rope to the first rider and hang on.
  - Ride a little to one side of the rider ahead and overlap wheels.
  - Ride a safe distance behind the rider ahead in a single file.

*Answers -  
1c, 2b, 3c, 4b, 5a, 6a, 7c, 8b, 9b, 10a, 11b, 12a, 13c*

### **True or False Safe Driving Quiz**

- A bicycle should be driven on the right-hand side of a street or highway.
- Bicycle drivers should obey all traffic signs and signals.
- Stop signs are round in shape.
- Pedestrians have the right-of-way on sidewalks and crosswalks.
- Bicycles should be "walked" across busy streets.
- The signal for a right turn is stretching the right arm straight out.
- Driving a bicycle at night without a front light or rear reflector is unsafe.
- It's safe for a bicycle driver to carry a passenger.
- You don't have to stop at an intersection if there is no traffic.
- Hitching a ride on another vehicle is safe if the driver is careful.

11. Bicycle drivers should give a hand signal before making a turn or stopping on the street.
12. It's safe to drive a bicycle that is in poor condition if you are a good driver.
13. If you're driving bicycles with friends, you should go single file.
14. Your chain should be loose enough to slip off easily.
15. It's okay to drive a bike in either direction on a one-way street.
16. If you live in the country, it's okay to drive on either side of the road.
17. Even a good driver should "walk" his bicycle through heavy traffic.
18. The faster you drive, the safer it is.
19. Bicycle drivers should stay at least three feet away from parked cars.
20. If you don't ride on busy streets, you don't need a horn or bell.

**Answers –**

- |           |           |                                                                                                    |           |          |           |          |           |
|-----------|-----------|----------------------------------------------------------------------------------------------------|-----------|----------|-----------|----------|-----------|
| 1...True  | 2. True   | 3. False, they have 8 sides. Railroad crossing signs are round.                                    |           |          |           |          |           |
| 4. True   | 5. True   | 6. False, it's extending the left arm with forearm raised and the palm of the hand facing forward. |           |          |           |          |           |
| 7. True   | 8. False  | 9. False                                                                                           | 10. False | 11. True | 12. False | 13. True | 14. False |
| 15. False | 16. False | 17. True                                                                                           | 18. False | 19. True | 20. False |          |           |

**Personal Bike Rack**

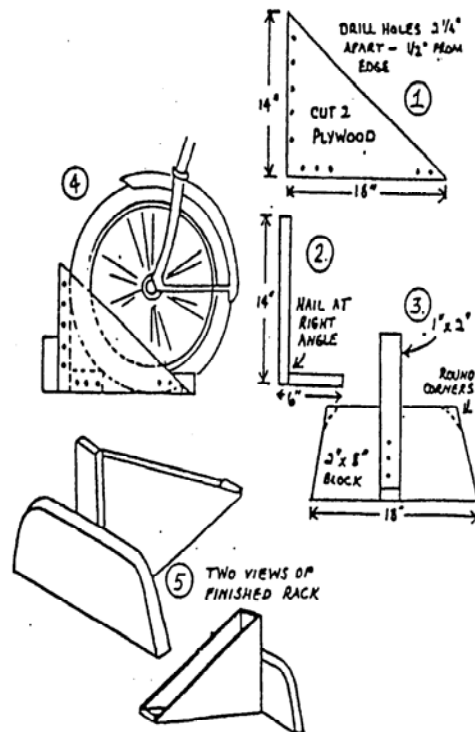

**Materials:**

- One 14" x 18" piece of 1/2" plywood;
- One 1" x 2" x 2'; one 2" x 8" x 18"
- No. 6 flathead screws (1-1 / 4" long);
- Six-penny nails;
- Varnish or paint;
- White glue or powdered resin glue.

1. Cut plywood triangles. Drill holes as show with a 5/32" drill bit. Paint or varnish the inside of plywood at this time. It will be difficult to do after rack is assembled.
2. Cut the 1" x 2" pieces. Nail the two longest pieces at right angles.
3. Cut the 2" x 8" piece. Attach the nailed 1"x2" with screws. Paint or varnish the 1" x 2" now. (Note the right angle is fastened to the 2" x 8" with screws from inside.)

4. Fasten the plywood triangles in place with screws through pre-drilled holes. Don't forget the small piece of 1" x 2" that joins the tips of the triangle.
5. Sand and complete paint or varnishing the piece.

## **Pack Summertime Activities**

### **Rally Night Preparations and Training**

**Pack Pool Party:** See Webelos Aquanaut section for aquatic ideas.

### **Pack Campout**

**Campfire Program:** see the "Fun at Camp" article

### **Paper Bag Kite**

For the kite, use a brown paper grocery bag with rectangular bottom. Cut a piece of cardboard the same size as the bottom. Cut an oval shape in the center of the cardboard. Using the cardboard as a pattern, cut a matching hole in the bottom of the bag. Punch a hole in each corner of the cardboard piece. Attach a long piece of string to each corner,

Glue cardboard to bottom of bag, matching the oval openings.

Take all free ends of the string and tie them together, so that all lengths are even. Tie them to the actual kite string, which is already

wound around a piece of wood or other kite string holder. Decorate as desired. **Have fun kite flying! !**

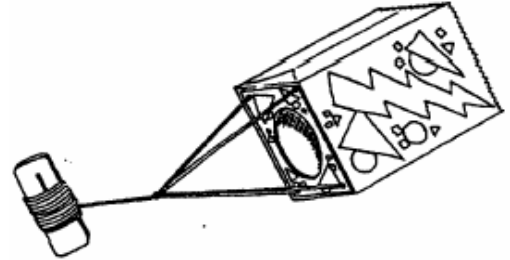

## **AUDIENCE PARTICIPATIONS**

### **Go-Cart Derby**

DOWN THE HILL "Zoo-oo-oo-mmmmmmm"

THE STRAIGHT AWAY "Swooo-oo-sshhh"

AROUND THE CORNER "Zip-zip-zip"

In a small town in the mid-west every year, there was held a big go-cart derby for all the boys in the town. This event was planned for many months in advance and was looked forward to with much anticipation by all the boys. The boys and their parents worked for months on building go-carts that would race DOWN THE HILL coast beautifully on THE STRAIGHT AWAY and go AROUND THE CORNER like winners. Each family worked hard to see if theirs could be the top winner in the derby. All over town, you could see the go-carts being tested DOWN THE HILL, THE STRAIGHT AWAY and AROUND THE CORNER.

One day, as they were making their test runs before the big race, one little boy named Johnny discovered that if he went DOWN THE HILL, AROUND THE CORNER, he would run farther THE STRAIGHT AWAY before his cart came to a stop. He had found the ideal spot for the race. After trying it several times, he hurried to tell some of the parents about this spot, hoping that they would hold the Derby there this year.

Several parents came out and watched Johnny's go-cart go DOWN THE HILL, AROUND THE CORNER and on THE STRAIGHT AWAY. They agreed that this would be a good spot to hold the race, except that Johnny had overlooked one thing – the go-carts were fine going DOWN THE HILL and AROUND THE CORNER, but it was when they came to a stop on THE STRAIGHT AWAY that they had problems. You see, they came to a stop right in the middle of a drive-in restaurant.

The parents got together and decided to talk to the restaurant owner. As a result, the owner agreed to close his restaurant during the Derby race and the whole town turned out to watch the go-carts race DOWN THE HILL, AROUND THE CORNER and into THE STRAIGHT AWAY. What a spectacular race it was!

After the race was over, everyone decided that, since the restaurant owner had been so generous to close his restaurant during the race, that they would all buy their dinner there that night. After all, driving those go-carts DOWN THE HILL, AROUND THE CORNER and into THE STRAIGHT AWAY had made all the boys very hungry, and the shouting and cheering done by the parents had helped them work up a good appetite, too. The restaurant owner was happy because he sold more hamburgers than he had ever sold in one day.

An agreement was made with the restaurant owner that every year they would hold their go-cart derby in that same spot, with the carts racing DOWN THE HILL, AROUND THE CORNER and into THE STRAIGHT AWAY to

the drive-in restaurant. They would all celebrate afterwards and buy those delicious hamburgers. So, you see, kindness and consideration to others can make things go better for everyone.

## The Big Wheel

BIG WHEEL: "Spin, spin"

WAGONS: "Getty-up Horsey"

AIRPLANES: " Zzooooom"

CARS: "Rattle, rattle, bang"

Man has invented different things that go and provide him with transportation down through the years. The early settlers used WAGONS, which took them from place to place and served its purpose well. Men like Henry Ford invented the CAR, which today is the most popular type of transportation. There were men like the Wright brothers, who pioneered the invention of the AIRPLANE. And there is a group of people, called the BIG WHEELS, who really don't go anyplace or do anything, but they like to feel important.

This story is about one of those BIG WHEELS who just sat and spun his wheels and felt so important while he was doing nothing at all. Everyone around him was working on new and better types of WAGONS, designing new and more efficient CARS, and designing and testing newer and faster AIRPLANES. But our BIG WHEEL just sat around feeling important, not doing anything to help anybody, while everyone else was doing the work. Somehow, he always seemed to get by and fool people into thinking that he was important because everyone around him was making progress. The BIG WHEEL depended on their brains and energy to make him look good. Finally, one day, something happened that changed things overnight for the BIG WHEEL.

Everyone who had been working on WAGONS, and CARS, and the AIRPLANES decided it was time to teach the BIG WHEEL a lesson. They were tired of him doing nothing except acting important. So they all became very busy and didn't pay any attention to him. When something came up, the BIG WHEEL found he couldn't rely on the others to answer questions and make him look important. Finally the BIG WHEEL realized he could not accomplish anything without help from the others. He realized he was making no contribution to the world at all. He was just sitting there spinning his wheel, while the others accomplished a lot on WAGONS, and CARS, and the AIRPLANES. BIG WHEEL felt very bad.

It was a hard lesson when BIG WHEEL finally realized something he should have known all along—if you're going to get anyplace in this world, you can't expect other people to do all the work for you. But it was a good lesson, too. Because when the BIG WHEEL, really look deep down within himself, he realized that, like the WAGON makers, and the CAR workers, and the AIRPLANE people, he too had special talents that he could use to contribute to the world.

## Travel

CAR – Honk-honk

BUS – Beep-beep

PLANE – Glide-glide

BOAT – Splash-splash

TRAVEL – All sounds at once

When you want to TRAVEL  
From place to place,  
There are many vehicles,  
That could join the race.  
There's the CAR....that comes,  
In many assorted sizes,  
With gadgets galore,  
And full of surprises,  
Or you could settle for a ride  
In a modern BUS...,  
And save yourself worry,  
And a whole lot of fuss.  
If a CAR...or a BUS...,  
Does not meet your needs,  
You can TRAVEL...in a PLANE...,  
At astonishing speeds.  
But before you choose to TRAVEL...,  
Over a route that's wet,

The finest of BOATS...,  
 Are yours to get.  
 When you want to TRAVEL...,  
 Whether near or far,  
 You can do it comfortably,  
 In a nice new CAR...,  
 If you listen when they say,  
 Leave the driving to us,  
 Then you certainly should TRAVEL...,  
 Around the place by BUS...,  
 But if you are one  
 That's always in a hurry,  
 Then take a PLANE...,  
 In your rush and scurry,  
 But if over the water you choose to ride,  
 Then pick a BOAT...,  
 And through the water you'll slide.  
 Whatever the transportation  
 You may chance to use,  
 When you TRAVEL...my friend,  
 'Tis yours to choose.

### The New Car

Tonight I'm going to read a little story about a couple that go shopping for a new car. But the story is really rather dull. I'd like you to help me make the story livelier by joining in when I read certain words. Whenever I say these key words, please follow these instructions; it'll help the story a lot!

- If you have blue eyes, whenever you hear the word BLUE pat the top of your head.
- If you have brown eyes, whenever you hear the word BROWN pat the top of your head.
- If you hear the word LEFT and you're left-handed, clap your hands.
- If you're right-handed, clap when you hear RIGHT.
- If you're under 20, stomp your feet when you hear the word NEW.
- If you're over 20, stomp your feet when you hear the word OLD.
- If you're a male, stand up when you hear MAN.
- If you're a female, stand up when you hear WOMAN.

(At this point the Narrator should practice with the audience, calling out the cue words having them respond with the appropriate action. The Narrator begins the story slowly and picks up speed Narrator pauses after each key word. )

One day a MAN and a WOMAN went looking for a NEW car. Their OLD one, which was a muddy BROWN was not running well. It LEFT much to be desired in the way of speed and safety, and they wanted another one RIGHT away. They wanted a bright BLUE one.

As they walked into the dealership, the WOMAN noticed a BLUE sports car on the showroom floor. "Darling" she said, "Look at that lovely NEW car RIGHT over there. Wouldn't it be perfect for us?"

"You may be RIGHT. It's a lot better looking than our OLD BROWN buggy. Unfortunately there's one problem. I've LEFT all my money at home," said the MAN.

"You LEFT it at home?" asked the WOMAN.

"Yes, it's RIGHT in the pocket of my NEW BROWN suit." said the MAN.

"Your NEW BROWN suit? Why I took that suit to the cleaners just this morning and I didn't notice any money in any of the pockets," said the WOMAN.

"But I'm certain I LEFT my money in the inside RIGHT pocket of my NEW BROWN suit," the MAN said as he scratched his head in wonder.

"Now wait a minute. Are you saying I'm not RIGHT? Are you saying I'm lying about this? MAN, oh MAN, oh MAN! You have a lot of nerve!" shrieked the WOMAN.

"Let's not argue. We're here to look at cars, and that BLUE one in the corner is a RIGHT nice model. And just think, if we buy the NEW BLUE car, we'll never have to worry about our OLD BROWN one again!"

After looking at the price of the NEW BLUE-car, and figuring out what they could get as a trade on their OLD BROWN one, the MAN and the WOMAN decide buying a NEW car would be the RIGHT move for them. But before they LEFT the dealer, they started questioning their decision. Would they be better off with their OLD

BROWN car if the NEW BLUE one didn't run RIGHT? Or what about a NEW BROWN one? How long before they thought of the NEW car as an OLD car? and would they ever feel BLUE about trading in their BROWN auto? BLUE or BROWN, OLD or NEW, what was RIGHT and which car did they want to be LEFT with?

The MAN and the WOMAN were so confused that they decided to sell their car and buy themselves bicycles. And that's just what they did. And they knew it was RIGHT...LEFT...RIGHT... LEFT (The narrator continues alternating between right and left until the audience realizes they are applauding the end of the story.)

## **ADVANCEMENT CEREMONIES**

### **Summertime Advancement Ceremony**

Often we find our Pack Meeting out-of-doors. A mailbox is fun, convenient and colorful for outside use. It is known as the 'Cubmaster's Mailbox'.

Decorate a standard mailbox with the Wolf, Bear, Bobcat, Webelos, and Arrow of Light stick-on emblems.

Place the award on a 3" x 5" card (one per Cub Scout) with the boy's name and put it in the mailbox. The Cubmaster then removes a card 'wondering what the mailman has brought'. The Cub Scout and his parents are then called forward and all are to participate in the presentation.

On the top is placed the Arrow of Light sticker. On the backside by the box flap is placed the Webelos sticker. The other three stickers are placed on the opposite side.

### **Dimming Campfire - Opening**

Equipment: Electric Campfire with dimmer switch, which an Akela may operate unseen. Start with it dim.

**Akela:** Tonight we have gathered at the ceremonial campfire to hear an ancient tale. It was once believed that a campfire had great magic. Of course it cooks our food, lights our way and wards off wild animals, but the magic of this Pack Council Fire is that it can light up our future! But only when we approach it after making a great accomplishment.

Will (Read names) and their parents please stand by their chairs? See how the fire burns only dimly when there are no advancing Scouts nearby? Now please come forward and join me at the fire's side. See how it has begun to burn brighter now! Have an Akela slowly increase the firelight

The fire tells us that you have completed all the requirements for your \_\_\_\_\_ rank. You have worked hard to be worthy of this great honor, so the fire has given us a sign that you will continue to find great joy and success in Cub Scouting. You will soon be on your way to earning the next rank in Scouting. The fire tells us you will do so!

Please stand. I present this award to your parents to present to you. Congratulations! (Akela sits again so he can work the controls to dim fire as Scouts leave.) I now dismiss you to your seats, and watch the fire as you leave its side! (Repeat as many times as needed for awards.)

### **Climbing A Mountain Peak**

Perfect ceremony for the outdoors!!

**CUBMASTER:** Cub scouting is an uphill trail, Bobcat to Arrow of Light. It is as if we were climbing a mountain peak. Before we begin our climb, we must first prepare ourselves for the task ahead.

Tonight we have several boys who, along with their parents, have decided to begin their ascent. These boys have learned the basic skills, which will provide a strong foundation for their Cub Scouting ventures. Will the following boys and their parents please come forward. (call names) With this foundation, I award to the parents and their Cubs their Bobcat award.

Lead congratulatory cheer.

Several of our boys have worked hard and made it to our first camp...Through their work they have earned the Wolf award. The achievements they learned will provide the direction to the next base. Will the following boys and their parents please come forward. (call names).

With the help of their parents, these boys have earned their Wolf award. I congratulate these boys and their parents and present them their Wolf award.

Lead congratulatory cheer.

Although the trail seems long, several of our boys have arrived at this midway camp. For having made their achievements, these boys will receive their bear award. They have come along way with their parents and have learned many skills, which will assist them in their next venture. Will the following boys and their parents please come forward. (call names).

Tonight these boys have earned their Bear award and will soon enter the trail to the peak. I present this award to the parents and their Cubs. Lead congratulatory cheer.



We have but one more camp to pass through before our final climb to the top, this is the Webelos camp. These boys have earned several achievements that will strengthen them for their ascent. Will the following boys, their parents and their Webelos Leader come forward. (call names)

WEBELOS LEADER: These boys have conditioned themselves in the manner of Cub Scouts and have earned their Webelos badge, (and/or list activity badges earned). It is from this camp that the final camp to the top is made. Congratulations!

CUBMASTER Lead congratulatory cheer.

## **GAMES**

### **Whirling Wheels**

Equipment: 1 beanbag per Six.

Relay, like the spokes of a wheel, facing in a clockwise direction with the Sixers in the center. The beanbags lie at the feet of each Sixer and when the leader gives the starting signal, they pick up the beanbag, run down the back of their Six and in a clockwise direction, round the wheel and back to the outside end of the Six. The beanbag is then passed up the Six to the Cub now at the center. This continues until all the Cubs have had a turn.

### **Roller Ball**

Materials: Board 3" x 24", 2 cans, and Ping-pong ball.

Cut out and sand the board. Glue two cans at either end. To play, hold the board in one hand and roll the ball back and forth.

### **Cubanapolis 500**

Make Cubmobiles from boxes. Designate a racetrack with straight ways and curves. Include a pit stop for each team. Drivers wear goggles, or glasses, lace up shoes and socks. The race is run in heats of 3 cars. Each heat consists of 3 laps and each driver must make one pit stop during the 3 lap race.

During the pit stop the pit crew must, clean the windshield (glasses), change the tires (remove shoes, turn socks inside out and put shoes back on), and refuel the driver (4 ounces of kool-aid through a straw).

### **Stock Car Racing**

Divide boys into teams. Each boy is given the name of a car and when that car is called, he must travel to the end of the area and back in the manner described.

Rolls Royce: This never goes wrong – the Cub runs.

Austin: Has a flat tire – Cub hops.

Morris: Is stuck in reverse – Cub runs backwards.

Ford: Very old model, can only go slowly – the Cub walks.

Mini: Only small – the Cub runs, crouched down.

Stock Car – everyone runs.

### **Car Relay**

Divide your boys into teams of 6 and have them select the part of an automobile.

Steering – gear is broken – walk zigzag.

Flat tire –Limp.

Gas Tank – water in tank two steps forward, one step back.

Transmission – Can't go forward – walks backward.

Battery – Dead – can't go at all

Tow – Pushes 5th player by placing both hands on player's waist.

### **Mile Walk**

This is a race to the end of the room and back, placing the heel of one shoe so that it touches the toe of the other at every step.

## **Car-Car**

Start by having everyone find a partner about the same height. One player is in front of the other facing in the same direction. The front player is the car. He places his bend arms chest high in front of him with palms out and open to act as bumpers, which he may need since his eyes will be closed. The driver will guide his car by the steering wheel (shoulders) nimbly through traffic with no collisions. After drivers take their cars for a little spin, have everyone freeze and reverse roles. If you don't have an even number of players, ask a threesome to invent a vehicle (truck, van, etc.).

## **Tire Games**

**Tire Sprint:** Racers line up with forward edge of tire at the starting line. On signal, they push tire forward and continue to push it across finish line. If necessary, establish lanes.

**Roll for Distance:** Each player rolls his tire separately and is entitled to run to gain speed and momentum but must stop at the stopping line while the tire rolls forward by itself.

**Roll for Accuracy;** Same as above, except tire is rolled at a target of 2 sticks set 3-4 feet apart and approximately 20 feet away.

**Moving Target:** Players take two turns rolling tire parallel to other players 15 – 20 feet away who try to throw balls or beanbags or broomsticks through the tire as it rolls by.

**Tire Wrestling:** Place two tires on the ground so they touch each other. One contestant stands in each tire. As the signal, they wrestle to throw or push their opponent out of his tire. The winner is the first to cause the other to fall or step out of his tire, provided he himself remains on his feet in his tire.

**Tire Bowling:** Bowl, using discarded tires in place of balls, with milk cartons or tin cans for bowling pins. Arrange "alley" on the ground with the bowling line 20 – 30 feet from the pins. Each bowler rolls two tires. Score as in bowling.

**Tire Rolling Relay:** Form teams and give the first player of each team a tire. Place a stake or chair opposite each team on the turning line. At the signal, the first player rolls his tire to the turning line, rolls it around the stake and back to the next player in line.

**Through the Tire Relay:** Establish a rolling line in front of the lines of dens. The first player of each team goes up to the rolling line with a tire. At signal he rolls his tire forward toward his team by giving it one shove. The players in turn then straddle-jump the tire. If the roller did not steer the tire exactly straight, the line must shift in order to be in line with their tire. If a player knocks the tire down in attempting to jump it, or if it falls over before he can jump it, he must recover the tire and give it to the player in front of him who rolls it for him and the rest of the team. The original roller then takes place at the front of the line. When the last man has jumped the tire, he rolls it to the starting line, and the action is repeated until the original roller has rolled the tire back to the starting line.

## **Bike Rodeo on a Sting**

Needed two pieces of string at least 30 feet long. Four coffee or juice cans filled with sand, you bike.

### **Straight Ride**

Lay the stings out parallel to each other 6 inches apart. Ride from one end to the other between Strings

**Variation:** Have a Cub from each team stand on chair at opposite ends of the room with a safety pin in his hand. Each team tries to pat the balloon to their own goalkeeper, who breaks it with the pin. A point is scored with each broken balloon.

**Coasting:** Take your bike back 10 feet from where the sting line begins. Pedal fast up to the stings and then coast between them. The longest coast wins.

**Slow Race:** Spread the stings 3 feet apart. Pedal slowly without touching your feet to the ground or touching the strings. Have a friend time you. The slowest time wins.

**Figure 8:** Line up the strings 9 feet apart and 18 feet long. Ride figure 8's inside the string lines without going outside the open ends.

**Quick Stop:** Ride up to one string from the side and brake 3 inches from the string.

**Escape Turn:** Ride up to one string from the side. When you are 1 foot short of the string, turn left. Next time turn right.

**Slalom:** Make one long line of both strings with loops every 6 feet. Ride back and forth across the stings between the loops without touching them. If you bike wheel touches the loop, you loose.

## Tire Repair

Sooner or later, in spite of your best efforts, you may have a flat tire. If you do any long distance riding, it is a good idea to carry a spare tube or repair kit, a wrench and a hand pump. To repair the tire, follow these directions?

1. Remove the wheel with the flat tire.
2. Completely deflate the tube. Remove the tire from the rim being careful not to damage the tube. Hold the tire on both sides and press the tire against the floor forcing the tire beads into the rim. Slide your hands towards the floor pulling on the tire as you proceed. When your hands are almost together, take a firm hold of the tire and roll the tire off the rim. Avoid the use of tools, especially screw drivers, to remove tires.
3. Repair the puncture with a good patch or replace the tube.
4. Check the inside of the tire to make sure it is free of any conditions which might damage the tube.
5. Dust the tube with talcum powder to prevent the tube from binding.
6. Check the rim to see that it is free of rust, dents and any rough or loose spoke heads.
7. Make sure that the rim strip covers all spoke heads.
8. Inflate the tube until it just starts to regain shape and insert tube in tire. Insert the valve through the rim and carefully mount the tire. Again, avoid the use of tools.
9. Inflate carefully to about 10 pound pressure and examine the tire making sure that the beads are seated and that the rim line is visible all the way around the rim.
10. Deflate the tube. This allows the tube to seat with out pinching or binding.
11. Again inflate to 10 pounds and check tire again.
12. Inflate to full pressure and replace wheel. Tighten axel nuts securely.

## Ways to Prevent Tire Damage

- **Don't jump curbs.**
- **Inflate tire to proper pressure.**
- **Don't ride double.**
- **Use only your hands to mount tires.**
- **Use a hand pump and tire gauge – don't use gas station air hoses.**
- **Avoid rough streets and alleys,**
- **Avoid skidding stops.**
- **Keep wheels aligned.**
- **Keep the valve stem straight.**

Remember: Store your bike properly. Although nothing can stop the eventual deterioration of rubber products, you can slow the process by keeping tires away from sunlight during long periods of storage and away from oily and greasy surfaces. For extended periods of storage, hang your bicycle or turn it upside down.

## SONGS

### Cub Scout Sports Song

(Tune: My Bonnie)

My baseball went over the fence  
My arrows are broken to bits  
My volleyball been deflated  
After riding a horse I can't sit

**Chorus:**

Belt loops, belt loops,  
I'll earn my sports pin today, today.  
Belt loops, belt loops;  
My letter is not far away

**Chorus:**

My bicycle has a flat tire  
My boomerang just won't return.  
They say that I've lost all my marbles  
And I still haven't gotten my turn.

**Chorus:**

My dog ate my ping pong paddle.  
My badminton birdie has flown.  
I sprained my right ankle while jogging  
And was stranded ten mile's from home.

**Chorus:**

They say that Cub Scout sports are fun.  
Some day I would like to know.  
I've been wandering around for an hour  
Just waiting for my Den to show.

### Take Me Out To The Ball Game

by: Jack Norworth and Albert Von Tilzer

Take me out to the ball game;  
Take me out with the crowd.  
Buy me some peanuts and cracker jack;  
I don't care if I never get back.  
Let me root, root, root for the home team;  
If they don't win it's a shame.  
For it's one, two, three strikes, you're out  
At the old ball game.

### Summer Fun In The Sun

(Tune: My Bonnie)

There's camping and fishing and swimming  
And soccer and baseball leagues too.  
And if you get up really early  
You'll enjoy a trip to the zoo.

**Chorus:**

Fun in the Sun  
Fun in the Sun  
For Cubs it's a natural thing to do  
Fun in the sun  
Fun in the sun  
But plan in for safety first, too.  
A water fight's great in the summer  
With water balloons galore.

But it's better to go to the park, cause  
In the house it can mess up the floor

**Chorus**

Water skiing is sure fun each summer  
And boat rides are much fun to take.  
But go over the rules for boat safety  
Or they'll be pulling you out of the lake.

**Chorus**

### Backyard Adventure

(Tune: Clementine)

**Chorus:**

In your backyard, in your backyard,  
You can have a lot of fun.  
If you look at what's around you  
You'll have fun 'til day is done.  
Did you ever watch an ant work?  
Have you listened to the bees?  
Have you watched birds build their nests?  
And been thankful for the trees?

**Chorus:**

After sunset, watch the stars shine.  
Nature's wonders you can see.  
Plant a garden, watch the corn grow,  
They'll be food for you and me.

**Chorus:**

If you'll just look all around you,  
Many new things you will see.  
Mother Nature's backyard's endless  
Always there for you and me.

### Camper's Lament

(Tune: "Battle Hymn Of The Republic")

The first raindrop began to fall as I arrived at camp.  
Then followed many million more as it began to pour!  
My father said, "Don't worry son; it won't be lasting long."  
When will I see the sun?

**Chorus:**

Pouring, pouring, not a single speck of light.  
Pouring, pouring, thru the day and thru the night.  
Pouring, pouring, wish my boots were water tight.  
When will I see the sun?  
First my socks, and then my pants were wringing, sopping  
wet.  
My sleeping bag's a water bed, a drenched cap on my  
head.  
The tent I slept in floated 'way; my food's a dripping goo.  
When will I see the sun?

**Chorus:**

Today's the day I'm leaving camp, and LO! what do I see?  
A ray of sun a-streaming thru a patch so bright and blue!  
The clouds are parting; dove's returning with an olive  
branch;  
I finally saw the sun!  
Chorus: (**Change last line to:** I finally saw the sun!)

## The Scout Who Never Returned

(tune: *Charlie on the MTA*)

Let me tell you a story of a Scout named \_\_\_\_\_  
On that tragic and fateful day;  
Put his Scout knife in his pocket;  
Kissed his dog and family;  
When to hike in the woods far away,  
Well, did he ever return?  
No, he never returned.  
And his fate is still unlearned;  
He may roam forever in the woods and mountains,  
He's the Scout who never returned.  
Now you citizens of (name town)  
Don't you think it's a scandal?  
How ol' (Scout's name) got lost that day?  
Take the right equipment: TAKE ALONG A BUDDY,  
When you hike in the hills that way.  
Or else you'll never return, no you'll never return.  
And your fate will be unlearned;  
You may roam forever in the woods and mountains,  
Like the Scout who never returned.

## People in a Family

Tune: Supercalifrafilistic

Mom and dad should take the time,  
You'll be glad you did,  
To be a parent and a friend  
Do something with your kid.  
One day they are tiny,  
and next day they are grown,  
And before you know it,  
You'll be all alone  
**Chorus:**  
People in a family should do a lot together  
In the house or out of doors  
No matter what the weather,  
Do not try to put it off  
It's either now or never,  
People in a family should do a lot together.  
Go to a museum, see a show,  
or ride a bike,  
Try your hand at fishing,  
Or at camping, or a hike.  
Swimming in a swimming pool  
Or skiing on the snow,  
Lots of things that you can do  
And places you can go.

## CUB GRUB

### Jet Swirl Pizza Appetizers

Similar to meat-filled calzones.

#### Ingredients:

- 1 (10 ounce) can refrigerated pizza crust dough
- ¼ lb. each thinly sliced Genoa salami, pepperoni sausage, provolone cheese
- ½ cup shredded mozzarella cheese

#### Directions:

Preheat oven to 350°F (175°C). Lightly grease a large baking sheet. Roll pizza crust dough into an approximately 10x14" rectangle on the baking sheet. Layer with Genoa salami, pepperoni and provolone cheese. Sprinkle with mozzarella cheese to within ½" of dough edge. Roll jelly roll style. Seal the edge with a fork. Bake in the preheated oven 25 minutes, or until golden brown. Slice into 1" pieces to serve. Original recipe yield: 5 servings.

### Flying Saucers

Hearty cookie with oats, coconut and wheat flakes cereal. Great for a snack.

#### Ingredients:

1 cup shortening	½ teaspoon baking powder
1 cup white sugar	½ teaspoon salt
1 cup brown sugar	2 cups rolled oats
2 eggs	2 cups whole wheat flake cereal
1 teaspoon vanilla extract	1 cup flaked coconut

#### Directions:

Preheat oven to 350°F (175°C). Grease cookie sheets. In a large bowl, cream together the shortening, white sugar and brown sugar until smooth. Beat in the eggs one at a time, Then stir in the vanilla. Combine the baking powder, baking soda and oats; stir into the sugar mixture. Fold in the wheat cereal and coconut. Drop dough by teaspoonfuls onto the prepared cookie sheets. Flatten slightly with a fork. Bake for 10 to 12 minutes in the preheated oven, or until light brown. Original recipe yield: 3 dozen.

## Apple Half Moons

Short Cut - try using chunky applesauce in place of apples. Or go wild with fruit preserves!

### Ingredients:

1/3 cup sour cream	1 tablespoon brown sugar
3/4 cup butter	1 1/2 cups all-purpose flour
1 egg yolk, beaten	1 teaspoon apple pie spice
1/4 cup raisins	1/4 cup white sugar
1 teaspoon vanilla extract	2 apples - peeled, cored and chopped

### Directions:

Stir together to blend sour cream, egg yolk and vanilla extract. In a large bowl stir together flour and sugar. Cut in 3/4 cup butter or margarine until like coarse crumbs. Mix in sour cream mixture until well blended. Divide dough in half and chill until easy to handle (3 hours or so).

### To Make Filling:

In small saucepan, melt the 1 tablespoon margarine. Add apples, raisins, brown sugar and apple spice and cook. Stir occasionally, until apples are fork tender. Remove excess liquid and cool.

### To Assemble Pastry

Roll each piece of dough to about 1/8" thickness and cut with 2 1/2" round cookie cutter. Place rounds 1/2" apart on ungreased cookie sheet. Place (skimpy) teaspoon of filling on each round and fold in half. Seal edges with fork. Bake at 350°F (175°C) for 10 to 12 minutes or until light brown. Remove and cool. Drizzle with lemon sugar icing made with 1/2 cup powdered sugar, 1 teaspoon lemon juice (fresh) and 1 tablespoon water. Mix to drizzling consistency. If too thick, add a little more water, if too thin, a little more confectioners' sugar. Original recipe yield: 4 dozen.

## Alien Meltdown

Snip one marshmallow into a triangular head and another into a torso with arms. Insert mini chocolate chip eyes. then assemble the Alien on a cookie for his "flying saucer". Place him in the microwave for about ten seconds on high and you've got alien meltdown!! Cool, eat and enjoy.

## Fried Saturn Rings

### Ingredients:

- Tart Apples
- Butter/Margarine
- Brown sugar

### Directions:

Core the apples, peel only if the skin is tough. Slice into 1/2 inch thick rings. Sauté in butter until barely tender. Turn over and cook until tender. Sprinkle brown sugar and cover until sugar melts.

## Asteroids

### Ingredients:

1 Cup sugar	1/4 cup margarine
1/4 cup milk	1 1/2 cups quick oatmeal
1/4 cup chopped nuts	2 1/2 tablespoons creamy peanut butter
1/2 teaspoon vanilla	

### Directions:

Combine sugar, margarine and milk in sauce pan, Boil 1 minute. Pour hot mixture over oatmeal and peanut butter. Add nuts and vanilla. Mix, drop by teaspoon onto wax paper. Let cool until firm.

## Fast Space Age Soup

### Ingredients:

1 can (14.5 oz) chopped tomatoes	1 pkg (10 oz) frozen corn
3 cans (14.5) chicken broth	1 pkg (10 oz) frozen cut green beans
1/3 cup alphabet noodles	1 tsp dry oregano
1/2 cup quick cooking pearl barley	1/4 tsp pepper.
8 oz frozen baby carrots	

**Directions:**

Mix tomatoes, chicken broth, noodles and barley in a pan. Bring to a boil over high heat stirring occasionally. Slice the carrots and add with corn and green beans. Season with oregano and pepper. Reduce heat and simmer for 10 minutes or until the barley is cooked.

## **STUNTS AND APPLAUSES**

### **APPLAUSES & CHEERS**

**Flower:** Like a flower blooming raise part way up in your chair, look around and then stand up quickly, yelling: "Sprong!"

**Handkerchief:** Throw a handkerchief up in the air with the instructions for applause to last until you catch it or it falls to the floor. Vary length of applause from long throw to short throw to NO throw.

**Bicycle:** Say: "Pump, pump, pump!"

**Nutty:** Cashew Cashew Cashew

**Balloon:** Make a fist. Put the thumb in your mouth and blow. Slowly open fingers to resemble enlarging balloon. Then flip out hand yelling, "Pop!" Or have air escape from mouth of balloon in a hiss.

**OCEAN APPLAUSE -** Best done with a large group; have first row sway from side to side; second row swaying in opposite direction; third row same as first, etc. The have them add sound effect: SWOOSH, SWOOSH, SWOOSH!!

**RAINSTORM APPLAUSE -** Start by gently patting knees alternately to simulate rain falling. Increase the noise by switching to hand clapping as the storm reaches its height. With a hand signal, have everyone shout "BOOM" to represent thunder. Gradually decrease the hand clapping and then pat the knees as the storm subsides.

### **RUN-ONS**

#### **Water! Water! , a classic run on**

A man, crawling across the stage: "Water, water!!"

Someone walks by, and the crawling man tugs on his pant leg. "Water, Water!"

Man walking by: "Sorry." He continues walking.

Another man walks by, the crawling man tugs on his pant leg: "Water, Water!"

Man walking by: "All I've got is this beef jerky, sorry." He keeps walking.

Another man walks by, the crawling man tugs on his pant leg: "Water, Water!"

Man walking by: "No, I don't have any." He keeps walking.

The crawling man sees a cup of water at the other end of the stage. "Water!!"

He painfully crawls over there. "Water! Water!"

When he reaches the water, he quickly stands up, dunks his comb in it, and uses it to comb his hair.

PROVERB: (by Den Leader) "As ye sow, so shall ye reap."

TRANSLATION: (by Cubs in unison) "What you seed is what you get!"

**Cub 1** What's the worst thing about being an octopus? ?

**Cub 2** Beats me. What's that??

**Cub 1:** Washing your hands before dinner!

**Cub 1:** What kinds of scale do giants weigh themselves on?

**Cub 2:** Is it a big scale?

**Cub 1:** Yeah, it's a Richter Scale.

**Cub 1:** Can you telephone from a submarine?

**Cub 2:** Of course! Who can't tell a phone from a submarine

**Cub 1:** What did George Washington say to his men before they got in the boat?

**Cub 2:** Beats me. What?

**Cub 1:** Men, get in the boat

**Cub 1:** What do you get if you cross a Cub Scout and a giraffe?

**Cub 2:** What?

**Cub 1:** A boy everyone looks up to

**Cub 1:** What kind of ship never sinks?

**Cub 2:** Friendship!

## JOKES & RIDDLES

What kind of a dog has no tail? Hot dog.  
What kind of an insect does your uncle like best? Ants  
What's the double tree? Pear  
What tree is nearest the sea? Beech  
What is a calendar tree? Date  
What tree will keep you warm? Fir  
What tree is used in kissing? Tulip  
What can move a tree but not a stone? *(The wind)*  
What do you call a web that a spider just finished weaving? *(A newly web)*  
Where is the ocean the deepest? *(On the bottom)*  
What keeps a forest from being silent? *(The bark of the trees)*  
Know who the kindest animal in the forest is? *(A skunk, he 'll give his scent to his worst enemy)*  
What happens when a skunk learns to fly? *(He raises a stink)*  
What is the best way to start a fire with two sticks? *(Make sure one of them is a match)*

## SKITS

### Keep America Beautiful Contest

**Cast:** Six Cubs in uniform.

**Props:** Comb and mirror for sixth Cub and a large box marked "TRASH!"

**Scene:** Five Cubs are sitting around a table tying knots or playing a simple game when the sixth Cub rushes in.

**Cub # 1:** *(Runs in, very excited)* Hey, you guys! Did you hear about the big contest?

**Cub # 2:** What contest? What's it about?

**Cub # 1 :** The "Keep America Beautiful Contest," that's what!

**Cub # 3:** Are there prizes? A contest is no good without prizes.

**Cub # 1:** Sure, lots of prizes. Neat ones like bicycles and CD players, and lots of other good stuff!

**Cub # 4:** *(Gloomily)* I bet it's hard. Contests with neat prizes are always hard.

**Cub # 1:** Nope! It's easy. Even the rules say it's SIMPLE - in big letters. The winner is the person who picks the easiest way.

**Cub # 5:** The easiest way to do what?

**Cub # 1:** The easiest way to keep America beautiful. That's what I've been talking about!

**Cub # 6:** *(With a swagger)* Ha! "Then I'm a cinch to win!

**Cub # 1:** Why's it so cinchy for you? What's your great way to keep America beautiful?

**Cub # 6:** *(Takes out comb and mirror and combs his hair)* See! That's the easiest way I know to keep America beautiful!

*The other Cubs look at him, then at each other.*

*Quickly they surround him and carry or drag him to a large box marked "TRASH" and dump him in*

**Cub # 1:** Like he said, guys, we're a cinch to win! That's the easiest way I know to keep America beautiful!  
*(They exit. laughing while Cub #6 stands up in the trash box with a disgusted look on his face.)*

### The Bicycle Shop

*This skit goes with the invention of the bicycle June 26, 1819.*

***This skit is potentially a grey area concern. If you do it, make it clear that the volunteer selected at the end is in on the joke. DO NOT SURPRISE THE VOLUNTEER***

**Setting:** The scene begins with three players on their hands and knees, in a row, as bicycles.)

**Shop Owner:** Well, there we are three brand new bicycles all set up for sale.

**Customer:** (Entering) Hi. I'd like to buy a bicycle.

**Shop Owner:** Sure thing, why don't you try them on for size?

*Customer sits on the first bike and it falls down.*

*The second is too big, while the third is too small.*

**Customer:** I sure like the first one, let me try it again.

**Shop Owner:** Why not? (Setting up bike again) There you are, it's all set up again.

*Customer sits on it, and again it falls down.*

**Customer:** I don't know. I really like this one but it keeps falling down. I'm afraid it's not made well enough.



**Shop Owner:** Our bicycles are all very well made. It was just assembled this morning, and it may need a little adjustment. Let me get some help.

*A volunteer is chosen from the audience, and is instructed to hold one 'wheel' of the now upright bicycle.)*

**Customer:** (Sitting on the bike) That's perfect now. What was the problem?

**Shop Owner:** Oh, we just need a big nut to hold it together!

## How Did You Get Here

Any number of Cubs can participate by dividing the lines accordingly.

Narrator introduces the skit by saying,

Transportation played a very important part in the settling of America.

How did you get here?

Cub #\_\_\_: If the Pilgrims came over on the Mayflower, how did the Scouts get here?

Cub #\_\_\_: I don't know. How?

Cub #\_\_\_: On Handy Crafts. (As he says this, a Cub comes on stage with a sample of a handicraft project and sign identifying it.)

Cub #\_\_\_: If the Pilgrims came on the Mayflower and Scouts came on Handy Crafts, how did the doctors get here?

Cub #\_\_\_: On Blood Vessels. (Cub dressed as a doctor enters.)

Cub #\_\_\_: How did the students get here?

Cub #\_\_\_: On Scholar Ships. (Cub enters, carrying a load of books.)

Cub #\_\_\_: How did all of the ordinary people get here?

Cub #\_\_\_: On Citizen Ships. (Cub enters, carrying a "Don't Forget to Vote" sign,)

Cub #\_\_\_: I know how the barbers got here.

Cub #\_\_\_: How?

Cub #\_\_\_: On Clipper Ships. (Cub enters, dressed as a barber, with towel and razor.)

Cub #\_\_\_: How did all the movie stars get here?

Cub #\_\_\_: On a Show Boat. (Cub enters, well dressed, wearing sunglasses.)

Cub #\_\_\_: I'll bet you can guess how all the hot heads got here. (Cub runs on stage, shaking his fist and pretending to quarrel with everyone.)

**All: On Steam Ships, of course! (They bow as the curtain closes.)**

## The True Hardship of Our Ancestors

Have boys holding pictures pertaining to their lines (with lines written on back).

- |                                          |                                             |
|------------------------------------------|---------------------------------------------|
| 1. Ancestors! O Ancestors!               | 21. Yes, we read of all your hardships      |
| 2. Your courage we admire...             | 22. But you beat us on one thing...         |
| 3. Not for the reasons history gives     | 23. You had the true original,              |
| 4. Do you our awe inspire!               | 24. Indoor-outdoor carpeting!               |
| 5. It's hard for us to understand        | 25. It's true you had no phones, no gas,    |
| 6. And know what it was like             | 26. No lights, no cars about...             |
| 7. You didn't have the things we have... | 27. But there's one thing you didn't have   |
| 8. A car, a plane, a bike!               | 28. That we couldn't do without!            |
| 9. We heard you crossed the mountains,   | 29. But one thing does amaze us,            |
| 10. Through forests thin and thick       | 30. When we read about your deeds;          |
| 11. In only covered wagons...            | 31. You made it through your travels,       |
| 12. Now, that was a trick!               | 32. Minus something each man needs!         |
| 13. We heard how then you had no roads,  | 33. Ancestors! O Ancestors!                 |
| 14. No highways lined with pines;        | 34. We salute you, long and hard!           |
| 15. One questions we must ask you...     | 35. You went across this whole wide land... |
| 16. What'd you do with all the signs?    | 36. Without a credit card!                  |
| 17. An then we read about your meals     |                                             |
| 18. Of wild bear... there's a stopper!   |                                             |
| 19. The one thing we say is this...      |                                             |
| 20. Your wife was quite a shopper!       |                                             |

## Tracking

Boys enter with magnifying glasses as if following a trail.

1. Look at those tracks!

2. Wow! They look like wolf tracks!
3. No, they look like bobcat tracks!
4. I think you're both wrong. I think they're bear tracks!
5. No, wolf tracks!
6. Bobcat tracks!
7. I told you, bear tracks!
8. *They continue arguing until they are suddenly run over by a train - several boys linked together making "Chug, chug, chug, choo, choo choo" sounds.*

**Den Chief:** (Raising his head and looking at the audience.) I think we were all wrong - they were **TRAIN TRACKS!** (He falls back down.)

## **Going the Distance**

**Personnel:** Any number of boys

**Opening:** All start out walking:

**1st Boy:** (stops) I'm thirsty. (All get a drink.) (Continue Walking.)

**2nd Boy:** (stops) I'm hot (All wipe off face.) (Continue Walking.)

**3rd Boy:** (stops) I'm hungry (All get something to eat) (Continue Walking)

**4th Boy:** (stops) My shoestring is undone (All tie shoestrings) (Continue Walking)

**Make up as many more things as you need so that every boy in your den has a part**

**Last boy** (*as boys approach the end of the stage*): This sure has been a long walk how far have we gone?

**1st Boy:** (Looking back) Across the stage!

## **CLOSING CEREMONIES**

### **Double Circle**

**PERSONNEL:** Entire pack - Cub Scouts, parents, and visitors.

**EQUIPMENT:** United States flag, four spotlights or four large flashlights

Have all present stand in a double circle, with Cub Scouts and other boys on the inside, and parents and visitors on outside. Focus spotlights or flashlights on the flag held in center of circle. Sing "God Bless America."

### **Closing Ceremony For Parents**

**Personnel:** 7 Cubs

**Equipment:** Game, Jackknife, book or pet, fishing pole

1. "What shall you give to one small boy? A glamorous game (holds up game), a tinsel toy,"
2. "A knife (holds up jackknife), a puzzle pack, a train that runs on curving tracks?"
3. "A picture book (holds up book), a real live pet... No, there's plenty of time for such things yet."
4. "Give him a day of his very own - Just one small boy and his parent alone."
5. "A walk in the woods, a romp in the park, a fishing trip (holds up fishing pole) from dawn to dark."
6. "Give the gift that only you can - Your companionship, your wisdom and your love"
7. (*Points to audience as he says his line*) "Games are outgrown, and toys decay - But he'll never forget if you give him a day."

## **Cubmaster's Minutes**

### **Sunscreen**

**Props:** A bottle of sunscreen

"Remember the last time you got a bad sun burn? It caused you much pain for several days didn't it? You probably didn't even realize that it was happening. Sunscreen could have prevented it. Our parents are like sunscreen. They can be used in situations we don't even know can hurt us. It pays to listen to our parents."

### **A Hiking Prayer**

Rabbi Nachman of Bratslav (1772-1811)

Master of the Universe

Grant me the ability to be alone;

May it be my custom to go outdoors each day

Among the trees and grass, among all living things.

And there may I be alone, and enter into prayer,  
To talk with the One to whom I belong.  
May I express there everything in my heart,  
And may all of the foliage of the field,  
All grasses trees and plants,  
May they all awake at my coming,  
To send the powers of their life into the words of my prayer  
So that my prayer and speech are made whole  
Through the life and the spirit of all growing things,  
Which are made as one by their Transcendent Source.

### **A Nature Minute**

I am part of Nature.  
I am part of everything that lives.  
I am bound together with all living things  
in air, in land, in water.  
My life depends upon Nature, upon its balance,  
upon its resources and upon the continuity of both.  
To destroy them is to destroy yourself.  
As a member of the human race,  
I am responsible for its survival.  
I am a part of Nature, and I will not destroy it.