



RETURN TO
MAIN
CONTENTS

WEBELOS

RETURN TO
SECTION
CONTENTS



AQUANAUT

AQUANAUT WORDSEARCH

In the puzzle below, locate the words that appear on the word list. You may find the words written backward, forward, up, down or diagonally. When you find a word, circle it on the puzzle and cross it off of the word list.

```

R A B A Q U A T I C S C D E B
O E R G H I J A K L M L M N U
W O S P Q R S R T U V I I W D
X Y Z C Z Y X G W V U F W T D
S R Q P U O N E M L K E S J Y
W I H G R E E T D C B L E A P
O B U D D Y B O A R D I F Z L
R A B C D E L R F G H N A I A
H I K L M E N O E R M E S Q N
T R S T K U V W X A Y Z M N Q
P Q R R S T U V S W T X Y Z A
B C O D S E F K G H I H I K L
Z N Y X N W V L O O P U I T S
S W I M I R Q P O N M L K N O
J G N I F O O R P N W O R D G

```

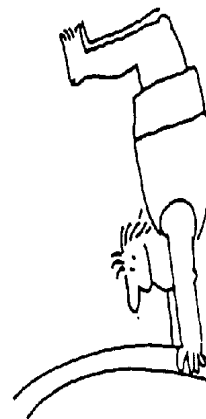

Word List

SAFE SWIM	GO	LIFELINE	RESCUE BREATHING
MASK	FINS	SNORKEL	DROWN PROOFING
AQUATICS	ROW	BUDDY BOARD	SWIM BUDDY PLAN
THROW	POOL	TARGET	

WATER FUN AND SAFETY QUIZ

Water Safety

For each statement, circle the correct answer, either DO or DON'T.

- | | | | |
|----|-------|----|---|
| DO | DON'T | 1. | Show off in the water. |
| DO | DON'T | 2. | Dive into strange or shallow waters. |
| DO | DON'T | 3. | Go in swimming right after eating. |
| DO | DON'T | 4. | Have your family physician give you a physical before starting a swimming course. |



WEBELOS



AQUANAUT

WATER FUN AND SAFETY QUIZ, continued

Boat Safety

For the statements below, circle the correct answer(s) to fill in the blanks.

1. In a rowboat, ____ people per seat is a safe rule. 1 / 2 / 3
2. ____ should wear a life jacket in a boat 20 feet or shorter. children / Scouts / adults
3. If your boat tips over, _____. swim to shore / hang on to the boat
4. Always keep a lookout for _____. other boats / swimmers / sharks

Swimming and Rescue Safety

Using words from the list below, fill in the correct letter for each description.

- _____ Rescue method where you extend something for the victim to grab onto.
- _____ This stroke is done on either your left or your right side.
- _____ This is the name for swimming with another person.
- _____ This rescue method involves providing a floating device to the victim.

- A. REACH B. SIDESTROKE C. BUDDY SYSTEM D. THROW

KIM'S GAME UNDERWATER

In five' deep water, make a small pile of five to ten familiar objects that do not float (spools, coins, metal nuts and washers, bolts, soda can full of water, etc.). Players swim out, surface dive to inspect the articles, and return. They then tell the leaders all the articles they remember seeing. The game ends with the swimmers retrieving all the objects.

TOWEL RESCUE

Play this game in chest-deep water. Divide the group into two teams. Put one member of each team some distance from his teammates and give him a towel. On signal, he walks or swims to his team, tosses the end of the towel to a teammate, and tows him back to the position from where he started. The "rescued" boy then becomes rescuer and repeats the actions, "saving" another team member. Continue until the whole team has saved and been saved.



RETURN TO
MAIN
CONTENTS

WEBELOS

AQUANAUT

RETURN TO
SECTION
CONTENTS



LIFELINE THROWING TEST

Make a target, as shown, and let the boys practice heaving a rope to a person in the water. Use a 25- to 30-foot rope and have the boys stand about 20 feet from the target. Weight the throwing end of the rope with a beanbag. The score for each heave is indicated by the numbers between the dowels. Dowels are 6" tall, placed 6" apart and painted as shown.

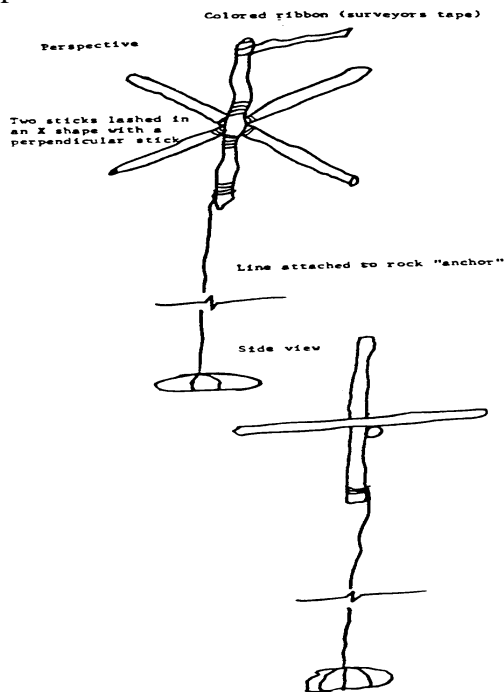
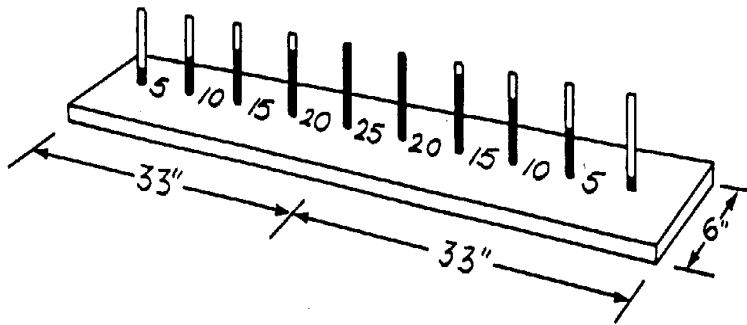

SWIMMING MARKERS

Make your own set of swimming markers to let others know what areas are safe for swimming or, if you are snorkeling, where they can locate you.

Materials needed:

18" to 24" long, upright sticks mounted with bottom portion longer than top to add stability
 brightly colored surveyors tape
 rope for lashing
 large rock
 nylon rope for tying to rock

Lash the sticks as shown. Tie surveyors tape to the top stick, leaving enough of a tail to act as a flag. Secure the nylon rope to the bottom of the middle stick and wrap securely around the rock. When complete, position in the water.

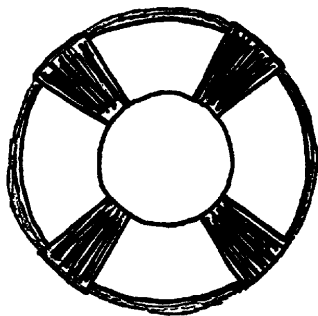

LIFE PRESERVER NECKERCHIEF SLIDE

Materials needed:

1 ring of foam core (2" across, 1/4" thick, 1" hole) glue
 6" white string 3/8" wide red tape white paint
 3" pipe cleaner for slide

Paint the ring and allow to dry. Wrap string around the outer edge of the ring and secure with red tape in 4 locations that form a cross. Bend the pipe cleaner and poke into the back of the ring to form the slide back. Secure the pipe cleaner ends with glue.



WEBELOS AQUANAUT



POOL PATROL

There are 12 rules being broken in this picture. There are clues for 10 of them. Super sleuth: Can you find all 12, including the two broken rules that have no clues?

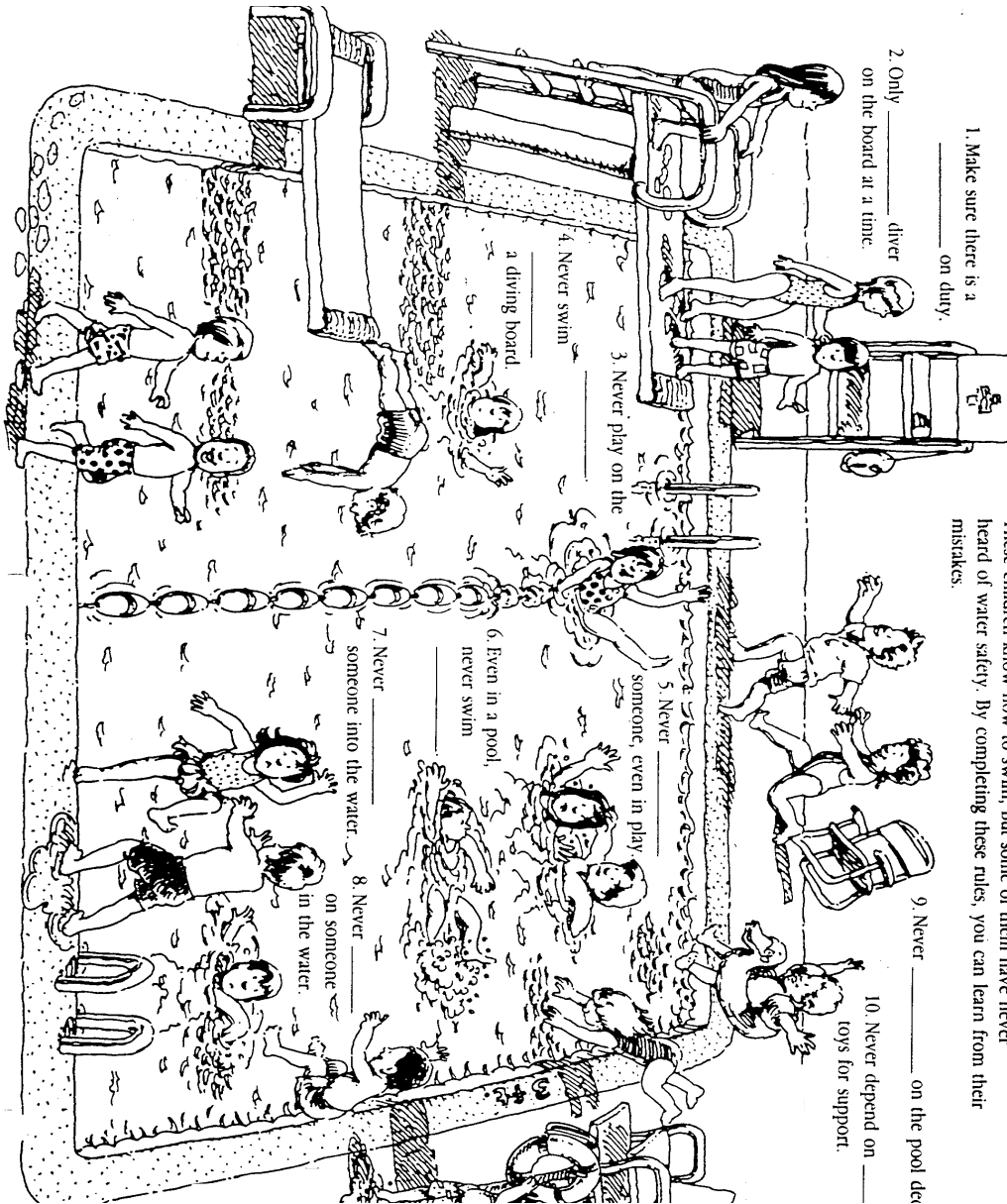

These children know how to swim, but some of them have never heard of water safety. By completing these rules, you can learn from their mistakes.

Pool Patrol

Answers:

- | | | |
|---------------|--------------------|--|
| 1. LIFEGUARD | 5. PUSH UNDERWATER | 9. RUN |
| 2. ONE | 6. ALONE | 10. FLOATATION |
| 3. POOL BOUYS | 7. SHOVE | 11. Never dive into shallow water |
| 4. AROUND | 8. JUMP | 12. Life preservers are for emergencies only |

